

Quik Bridge™ Learn Mode Repeater

Document Number: 46-849 Rev. G
November 1999

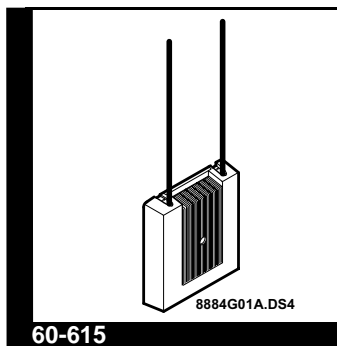

INSTALLATION INSTRUCTIONS

Product Summary

The purpose of the Quik Bridge Learn Mode Repeater is to receive and retransmit signals from Learn Mode sensors, wireless touchpads, and other repeaters. The repeater is ideal for the following applications:

- ③ Installations where sensors are beyond panel reception or fail sensor test.
- ③ As a substitute for preamps in installations where panel antennas are shielded by metal.

The repeater may be used in one of the following modes:

Intelligent mode: In this mode, the repeater retransmits signals received from sensors, wireless touchpads, and intelligent mode repeaters that have been “learned” into the repeater memory. An intelligent mode repeater may “learn” a maximum of 16 sensors/touchpads and 2 intelligent mode repeaters.

Sensor mode: In this mode, the repeater will retransmit all signals received from sensors and wireless touchpads but will not retransmit signals received from other repeaters.

Repeater Features

Repeater features include the following:

- ③ Transmittal of hourly supervisory reports to the panel.
- ③ A tamper switch that causes an alarm transmission if the repeater cover is removed.
- ③ Support for a rechargeable backup battery.
- ③ A dual-antenna receiver, which improves reception through spatial diversity.
- ③ Transmittal of a low battery trouble report when the backup battery is low (optional).
- ③ Transmittal of an AC power failure alarm when AC power has failed for more than 15 minutes (optional).
- ③ Learn Mode technology, making installation easy.

Powering Options

- ③ 15–16.5 VAC Class II Transformer with 2 VA rating or higher, when using a backup battery.
- or-- 9–16.5 VAC Class II Transformer with 2 VA rating or higher, when not using a backup battery.
- or-- 12 VDC supply.

Compatibility

- ③ All current ITI Learn Mode sensors (except RF Meterlink) and wireless touchpads.
- ③ CareTaker® *Plus*, WatchGard, and Security Pro 4000 panels with software version 4.0 or later.
- ③ SX-V *Special* with software version 7.0 or later.
- ③ Safewatch Custom RF with software version 2.1 or later.
- ③ UltraGard™ with software version 1.0 or later.

Tools and Accessories Needed

Included with Repeater

- ③ Mounting screws and anchors

- ③ Spring for tamper switch
- ③ 2 antennas

Not Included with Repeater

- ③ Phillips screwdriver
- ③ Small standard screwdriver
- ③ 2-conductor, 12–22-gauge, stranded wire
- ③ Class II Transformer or power supply
- ③ Backup battery (optional)
- ③ RF Sniffer (60-401, optional)

Overview of Repeater Operation

DIP Switches

There are 8 DIP switches (numbered 1–8 from left to right) on the repeater circuit board that are used to do the following:

- ③ Set the repeater mode for sensor or intelligent mode.
- ③ Configure the repeater for “learning” and deleting sensors (intelligent mode only).
- ③ Enable or disable low battery reporting.
- ③ Enable or disable AC power failure reporting.

A DIP switch is “ON” when flipped up towards the antennas or “OFF” when flipped down. The repeater will only “read” the DIP switches when the tamper switch is activated or upon power-up.

Certain DIP switch settings are not valid. For example, setting the DIP switches for “learning” or deleting sensors while in sensor repeat mode will make the DIP settings invalid. The LED blinks continuously while DIP switch settings are not valid until the repeater is powered down and powered up with a valid setting.

LED Indications

The purpose of the LED is to indicate certain actions of the repeater. Table 1 describes all possible LED indications:

Table 1. LED Indications

LED	Means this...
ON	Repeater is powered up and passed self-test.

Table 1. LED Indications

LED	Means this...
OFF	Repeater is not powered or failed to power up.
Single Blink	Repeater received a signal from a Learn Mode transmitter, or an intelligent mode repeater “learned”/deleted a sensor or touchpad.
Double blink	Intelligent mode repeater “learns”/deletes another intelligent mode repeater.
Fast (5/sec.) Constant blinking	DIP switch settings are incorrect or repeater failed self-test at power up.
Slow (1/sec.) Constant blinking	Intelligent mode repeater is deleting all transmitters from memory. LED may continue flashing for up to 10 seconds after another mode is selected with the DIP switches.

Modes of Operation

The repeater may be used in one of two modes: intelligent mode and sensor mode.

Intelligent Mode

The intelligent mode is the recommended mode of operation. In this mode, the repeater only retransmits signals received from sensors, touchpads, and intelligent mode repeaters that are “learned” into memory. A maximum of 16 sensors/touchpads and 2 intelligent mode repeaters may be learned into an intelligent mode repeater.

Intelligent mode repeaters provide special features for “learning” and deleting transmitters.

The advantages to using repeaters in intelligent mode include the following:

- ③ The range of the system can be increased by adding additional intelligent mode repeaters. A maximum of 31 intelligent mode repeaters may be cascaded within a system.
- ③ Intelligent mode repeaters retransmit signals from “learned” transmitters, which reduce RF traffic.

Sensor Mode

In sensor mode the repeater retransmits signals received from all sensors and touchpads but does not retransmit signals from other repeaters. Avoid installing more than one sensor mode repeater per system. Sensor mode repeaters must be installed within panel reception because their signals cannot be repeated.

The only advantage of using a repeater in sensor mode rather than in intelligent mode is that sensors and touchpads are not “learned,” which reduces installation time.

Testing the Transmitter and Receiver

Two tests must be performed during the installation to insure that each transmitter (sensor, touchpad, or repeater) is received by the intended receiver (control panel or repeater).

Note: It takes two people to perform the following tests because of the distances between devices.

Dealer Sensor Test

This test checks the communication link between the control panel and the transmitters (sensors, touchpads, and repeaters). The transmitters have to be “learned” into the panel before this test is performed.

Transmitters do not have to pass this test if their signals are received and retransmitted by a repeater.

Refer to the particular panel installation manual for the Dealer Sensor Test procedure.

Repeater Reception Test

This test checks the communication link between a repeater and other transmitters. The repeater LED blinks for each transmission (packet) received from a sensor, touchpad, or repeater.

Note: One person must activate (trip) the transmitter while another person counts the number of LED blinks at the *receiving* repeater.

For intelligent mode repeaters, the transmitters should not be “learned” into the repeater before this test is performed.

All transmitters that fail the Dealer Sensor Test must pass this test for the *receiving* repeater.

To perform a repeater reception test:

- 1) Take the cover off of the *receiving* repeater.
 - 2) For sensors with a tamper switch, remove the cover from the sensor. This causes an alarm transmission and the repeater should receive 7–8 packets (indicated by 7–8 LED flashes) in order to pass this test.
- or-- For sensors without a tamper switch, activate an alarm. The repeater should receive 7–8 packets (indicated by 7–8 LED flashes) in order to pass

this test.

- or-- For panic buttons, hold down the button for 5 seconds and release it. The repeater should receive 14–16 packets (indicated by 14–16 LED flashes) in order to pass this test.
- or-- For touchpads, hold down an emergency button for 5 seconds and release it. The repeater should receive 7–8 packets (indicated by 7–8 LED flashes) in order to pass this test.
- or-- For intelligent mode repeaters, hold down the tamper switch for 5 seconds and release it. The *receiving* repeater should receive 14–16 packets (indicated by 14–16 LED flashes) in order to pass this test.

Installation Overview

Install the repeater in the following order:

- 1) Determine which transmitters need a repeater.
- 2) Connect antennas.
- 3) Connect power.
- 4) Program the repeater into the panel.
- 5) Install the repeater using one of the following procedures.

Intelligent Mode:

- a. Set the repeater number.
- b. “Learn” the repeater into other repeaters (optional).
- c. Choose a location for the repeater.
- d. Test the repeater transmitter.
- e. Test the repeater receiver.
- f. Learn the transmitters into the repeater.
- g. Delete transmitters from the repeater (optional).

Sensor Mode:

- a. Set the repeater number.
 - b. Choose a location for the repeater.
 - c. Test the repeater transmitter.
 - d. Test the repeater receiver.
- 6) Enable AC power failure reporting (optional).
 - 7) Enable low battery reporting (optional).
 - 8) Permanently mount the repeater.

Installing Repeaters

Determine Which Transmitters Need a Repeater

The first step of the installation is to determine which sensors and touchpads need their signals repeated.

To determine which sensors and touchpads need a repeater:

- 1) “Learn” all of the system sensors and touchpads into the control panel.
- 2) Mount the sensors and touchpads in the desired locations.
- 3) Remove power from all repeaters.
- 4) Perform a Dealer Sensor Test on all of the system sensors and touchpads.

If all of the system sensors and touchpads pass this test, a repeater is not necessary with the system. Sensors and touchpads that fail this test will need their signals retransmitted by one or more repeaters. Keep track of which transmitters are distant because only the distant transmitters have to be tested with the repeater receiver.

Connecting Antennas to the Repeater

To connect antennas to the repeater:

- 1) Remove the cover by pressing down on the top center of the cover, and pull it away from the base (see Figure 5).
- 2) Loosen the **inside** terminals of the left and right antenna terminal blocks.
- 3) Insert an antenna into each **inside** terminal.
- 4) Tighten down the terminal screws (see Figure 1).

- 5) Set all of the DIP switches to the OFF position for now.

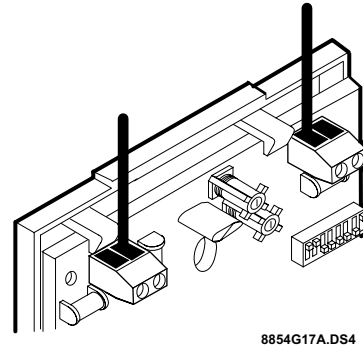

Figure 1. Connecting Repeater Antennas

Connecting Power

The three methods for providing power to the repeater are:

- ③ A 9–16.5 VAC Class II Transformer with a minimum 2 VA rating, when not using a backup battery (see Figure 2).

For example, 9 VAC Class II Transformer, 15 VA UL (60-515) or 9 VAC Class II Transformer, 15 VA CSA (60-516).

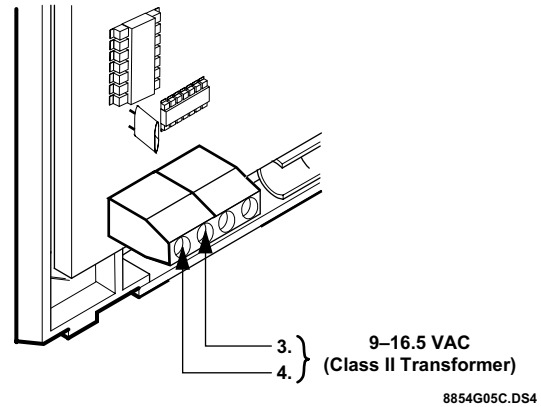

Figure 2. Connecting Class II without Battery

- ③ A 15–16.5 VAC Class II Transformer with a minimum 2 VA rating and a 12V lead acid battery with a minimum 1.3 Ah rating for 24-hour backup (see Figure 3).

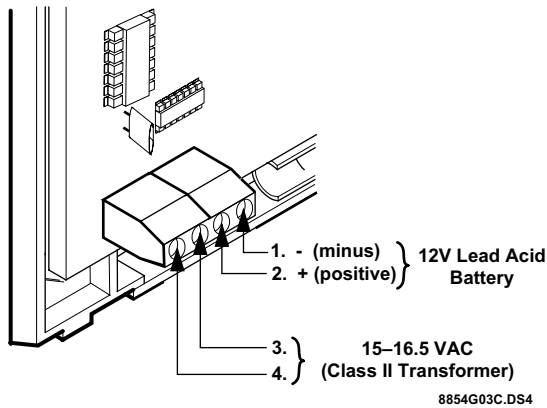

Figure 3. Connecting Class II with Backup Battery

- 3) Standard 12 VDC supply that provides at least 50 mA (see Figure 4).

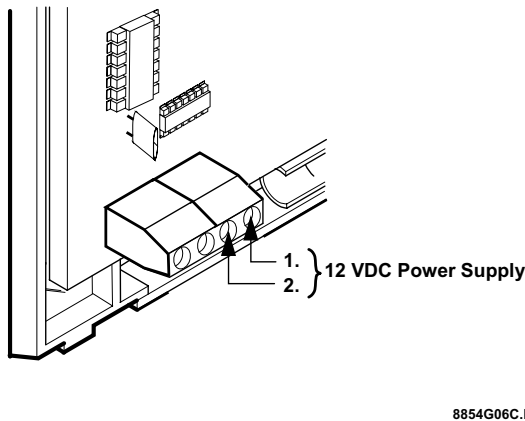

Figure 4. Connecting 12 VDC Power Supply

To connect a transformer:

- 1) Run a 2-conductor, stranded, 12–22 gauge wire to make the connections.
- 2) Connect the wires to repeater terminals 3 and 4 (see Figure 2 or 3).
- 3) Connect the other end to the two terminals on the AC transformer.
- 4) Plug the transformer into a non-switched outlet.
- 5) Check the status of the green LED on the repeater.

To connect the battery or DC power supply:

- 1) Run a 2-conductor, stranded, 12–22 gauge wire to make the connections.
- 2) Connect the wires to repeater terminals 1 and 2 (see Figure 3 or 4).
- 3) Connect the other end to the battery or DC power supply.

- 4) Check the status of the green LED on the repeater.

Programming the Repeater into the Panel

Before the panel can supervise the repeater, the repeater must be programmed into panel memory.

To program the repeater into the panel:

- 1) Refer to the panel installation instructions for the sensor programming procedure.
- 2) When the panel prompts you for a group number, we recommend that you use group number 4. Group number 4 supervises the repeater and causes an instant alarm if the tamper is tripped.
- 3) Trip the repeater tamper when the procedure prompts for the sensor activation.

Installing an Intelligent Mode Repeater

This section describes how to install a single intelligent mode repeater. By performing the tests described in this section, you can determine if additional repeaters are necessary. Repeat the installation procedure for each intelligent mode repeater you add to the system. If you are installing a sensor mode repeater, skip to “Installing a Sensor Mode Repeater.”

Setting the Repeater Number for Intelligent Repeat Mode

- 1) Set DIP switches 4-8 to a unique, non-zero repeater number (see Table 3).

Note: When “learning” repeaters into other repeaters, the repeater number at the destination repeater must be less than the repeater number of the source repeater. For example, you can “learn” repeater 2 into repeater 1, because 2 is greater than 1. Refer to the installation example at the end of this document (see Figure 8) and note that intelligent mode repeaters “cascade” toward the panel in descending order.

Note: If fewer than 16 intelligent mode repeaters are needed for the system, plan to assign only even numbers to the repeaters. This method allows for an additional repeater to be retro-fitted between two cascaded repeaters, if necessary.

- 2) Set DIP switches 1–3 to the OFF position (see Table 2).

- 3) Activate the tamper switch.

Table 2. Intelligent Mode DIP Switch Settings

Mode	DIP Switch								
	1	2	3	4	5	6	7	8	
Intelligent	off	off	off	set to the repeater number					

Table 3. Selecting a Repeater Number for Intelligent Mode

Repeater Number	DIP Switch Settings				
	4	5	6	7	8
1	off	off	off	off	on
2	off	off	off	on	off
3	off	off	off	on	on
4	off	off	on	off	off
5	off	off	on	off	on
6	off	off	on	on	off
7	off	off	on	on	on
8	off	on	off	off	off
9	off	on	off	off	on
10	off	on	off	on	off
11	off	on	off	on	on
12	off	on	on	off	off
13	off	on	on	off	on
14	off	on	on	on	off
15	off	on	on	on	on
16	on	off	off	off	off
17	on	off	off	off	on
18	on	off	off	on	off

Table 3. Selecting a Repeater Number for Intelligent Mode (Continued)

Repeater Number	DIP Switch Settings				
	4	5	6	7	8
19	on	off	off	on	on
20	on	off	on	off	off
21	on	off	on	off	on
22	on	off	on	on	off
23	on	off	on	on	on
24	on	on	off	off	off
25	on	on	off	off	on
26	on	on	off	on	off
27	on	on	off	on	on
28	on	on	on	off	off
29	on	on	on	off	on
30	on	on	on	on	off
31	on	on	on	on	on

“Learning” an Intelligent Mode Repeater into another Intelligent Mode Repeater

If this intelligent mode repeater transmits directly to the panel, skip to “Choosing a Location for an Intelligent Mode Repeater.”

If the signals from this repeater need to be repeated by another (destination) repeater, then “learn” this repeater into the *destination* repeater.

To “learn” a *source* intelligent mode repeater into a *destination* intelligent mode repeater:

- 1) Set the DIP switches on the destination repeater for “*learn*” transmitters (see Table 4).
- 2) Activate the tamper switch on the destination repeater that is about to “learn” transmitters to configure the repeater for “learning.”
- 3) Activate the tamper switch on the source repeater.
- 4) After “learning” the repeater(s), set DIP switches 1–3 back to the OFF position.
- 5) Activate the tamper switch on the destination repeater. This causes the repeater to stop “*learning*” transmitters.

Note: The repeater LED blinks twice after “learning” a repeater.

Table 4. DIP Switch Settings for “Learn” Transmitter

Action	DIP Switch								
	1	2	3	4	5	6	7	8	
“Learn” Transmitter	off	off	on						set the repeater number

Choosing a Location for an Intelligent Mode Repeater

To select a mounting location for an intelligent mode repeater, use the following guidelines.

- ③ Before permanently mounting, test the repeater transmitter and receiver in several locations.
- ③ Select a location that has access to an AC outlet or DC power supply.
- ③ If this repeater transmits directly to the panel, locate it between the panel and distant transmitters but within panel reception.
- ③ If this repeater is being repeated by other repeaters, locate it between the *destination* repeater and distant transmitters but within repeater reception.

Note: After a location has been selected, temporarily mount the repeater using a piece of double-sided tape or a single mounting screw (refer to “Mounting the Repeater”). This allows you to test the repeater transmitter and receiver at the location before permanently mounting.

Testing an Intelligent Mode Repeater Transmitter

After the repeater is temporarily mounted, perform the appropriate test to determine if the signals transmitted by the repeater are received by the intended receiver (control panel or another intelligent mode repeater).

To test signals sent directly to the control panel:

- ③ Perform a Dealer Sensor Test to determine whether or not the signals are received by the control panel.

If the repeater passes this test, skip to “Testing the Intelligent Mode Repeater Receiver.”

If the repeater fails this test, it is located too far from the control panel and must be relocated

closer. Repeat until the repeater passes this test.

To test signals sent to another intelligent mode repeater:

- ③ Perform a Repeater Reception Test to determine whether or not these signals are received by the *destination* repeater.

If the repeater passes this test, skip to “Testing the Intelligent Mode Repeater Receiver.”

If the repeater fails this test, it is located too far from the *destination* repeater and must be relocated closer. Repeat until the repeater passes this test.

Testing an Intelligent Mode Repeater Receiver

To test an intelligent mode repeater receiver:

- 1) Test the repeater receiver by performing a Repeater Reception Test on the distant sensors and touchpads. This test indicates which sensors and touchpads may be “learned” into this repeater. Only sensors and touchpads that pass this test should be “learned” into this repeater. If any one of the distant sensors or touchpads fail this test, do one of the following:
 - ③ Relocate the intelligent mode repeater and repeat the procedure for testing the repeater transmitter and receiver.
 - ③ “Learn” the sensors and touchpads that passed this test and use additional intelligent mode repeaters.

“Learning” Transmitters into an Intelligent Mode Repeater

Sensors and touchpads that passed the repeater reception test should be “learned” into the repeater.

To “learn” sensors and touchpads into an intelligent mode repeater:

- 1) Set the DIP switches on the repeater to “*learn*” transmitter (see Table 4).
- 2) Activate the tamper switch on the repeater that is about to “learn” transmitters to configure the repeater for “learning.”
- 3) Trip the transmitters that are to be “learned” into the repeater in the same way you would with the control panel.
- 4) After “learning” the transmitters, set DIP switches 1–3 back to the OFF position.

- 5) Activate the tamper switch on the repeater. This causes the repeater to stop “learning” transmitter.

Note: The repeater LED blinks once when it “learns” a sensor or touchpad.

Deleting Transmitters from an Intelligent Mode Repeater

To delete a sensor, touchpad, or intelligent mode repeater from the memory of an intelligent mode repeater:

- 1) Set the DIP switches on the repeater to *delete transmitter* (see Table 5).
- 2) To configure the repeater for deleting, press and release the tamper switch on the repeater which is about to delete transmitters.
- 3) Trip the transmitters that are to be deleted from the repeater in the same way they were tripped for “learning.”
- 4) After deleting the transmitters, set DIP switches 1–3 back to the OFF position.
- 5) Press and release the tamper switch. This causes the repeater to stop *deleting transmitters*.
- 6) Wait for LED to stop blinking. Remove power from repeater for five seconds; then reactivate power.

The repeater LED blinks once when it deletes a sensor or touchpad. It blinks twice after deleting a repeater.

Table 5. DIP Switch Settings for Delete Transmitter

Action	DIP Switch								
	1	2	3	4	5	6	7	8	
Delete Transmitter	off	on	on						set to the repeater number

To delete all of the sensors, touchpads, and intelligent mode repeaters at once, do the following:

- 1) Set the DIP switches on the repeater to *clear memory* (see Table 6).
- 2) Press and release the tamper switch. The LED begins to blink.
- 3) Set DIP switches 1–3 to the OFF position after the LED on the repeater starts blinking.

- 4) Press and release the tamper switch again.
- 5) Wait for LED to stop blinking. Remove power from the repeater for five seconds; then reactivate power.

Note: The repeater LED may continue to blink for up to ten seconds after the procedure is completed.

Table 6. DIP Switch Settings for Clear Memory

Action	DIP Switch								
	1	2	3	4	5	6	7	8	
Clear Memory	on		on						set to the repeater number

Adding Additional Intelligent Mode Repeaters

If there are remaining distant sensors that are not within repeater reception, you must add additional intelligent mode repeaters to the system. Repeat the above installation procedure for each repeater.

Installing a Sensor Mode Repeater

This section describes how to install a single sensor mode repeater. By performing the tests described in this section, you can determine if additional repeaters are necessary. Repeat this installation procedure for each sensor repeater you add to the system.

Setting the Repeater Number for Sensor Repeat Mode

To set the repeater number for sensor repeat mode:

- 1) Set all of the DIP switches to the OFF position (see Table 7).
- 2) Activate the tamper switch.

Table 7. Sensor Mode DIP Switch Settings

Mode	DIP Switch							
	1	2	3	4	5	6	7	8
Sensor Repeater	off	off	off	off	off	off	off	off

Choosing a Location for a Sensor Mode Repeater

To select a mounting location for a sensor mode repeater, use the following guidelines:

- ③ Before permanently mounting the repeater, test the repeater transmitter and receiver in several locations.
- ③ Select a location that has access to an AC outlet or DC power supply.
- ③ Locate the repeater between the control panel and the distant sensors/touchpads that you want repeated.

Testing a Sensor Mode Repeater Transmitter

To test a sensor mode repeater transmitter:

- ③ Perform a Dealer Sensor Test on the sensor mode repeater. If it fails this test, the repeater is located too far from the control panel and must be relocated closer. Repeat until the repeater passes this test.

Testing a Sensor Mode Repeater Receiver

To test a sensor mode repeater receiver:

- 1) Perform a Repeater Reception Test on the distant sensors and touchpads. If any one of the distant sensors or touchpads fail this test, do one of the following:
 - ③ Relocate the sensor mode repeater closer to the distant sensors/touchpads and repeat testing procedure for the repeater transmitter and receiver.
 - ③ Repeat the installation using intelligent mode repeaters.

Final Test

In order to ensure that sensors and transmitters have been deleted, remove power for five seconds and reactivate it. Then perform a sensor and transmitter test.

Enabling the AC Power Failure Reporting Option

When AC power failure is enabled, the repeater reports an alarm transmission to the control panel after the repeater has lost AC power for more than 15 min-

utes.

To enable AC power failure reporting:

- ③ Set DIP switch 1 to the ON position.

Note: This option should only be enabled when using a backup battery and a 15–16.5 VAC transformer.

Enabling the Low Battery Reporting Option

When low battery reporting is enabled, the repeater reports the status of its backup battery to the control panel.

To enable low battery reporting:

- ③ Set DIP switch 2 to the ON position.

Note: This option should only be enabled when using a backup battery and a 15–16.5 VAC transformer.

Mounting the Repeater



You must be free of static electricity before handling circuit boards. Discharge yourself by touching a bare metal surface, or wear a grounding strap.

To disassemble and mount the repeater:

Remove the enclosure cover by pressing down on the top center of the cover and pull the cover away from the base (see Figure 5). Set the cover aside.

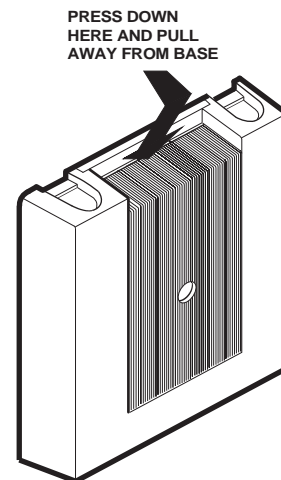

Figure 5. Removing Enclosure Cover

- 2) Press down on the lower-right corner of the base until the latch releases the circuit board (see Figure 6).

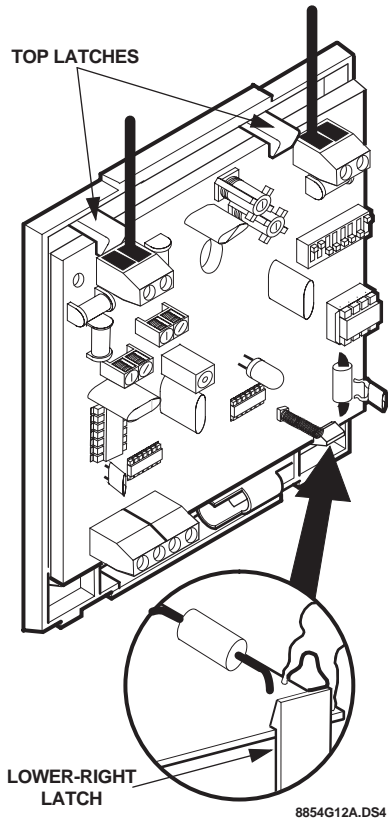

Figure 6. Latch Locations

- 3) Remove the circuit board from the base by gently lifting the circuit board by the terminal block until the top two latches release the board (see Figure 6). Place the circuit board in the repeater cover.



Placing the circuit board in direct contact with a metallic surface (such as a ladder) can permanently damage the repeater.

- 4) Hold the base against the mounting surface and mark the three mounting holes (see Figure 7).

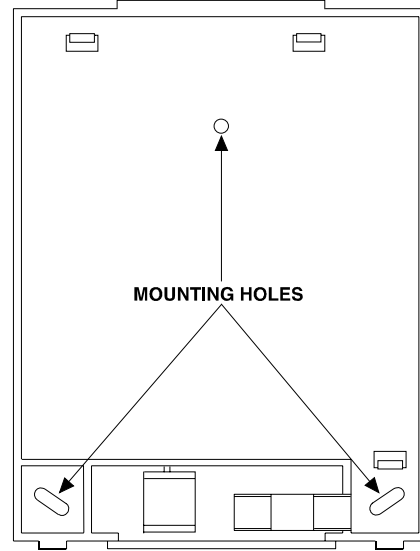

Figure 7. Mounting Hole Locations

Note: Remember to leave at least 10 inches above the repeater for the antennas.

- 5) Remove the base and install anchors (included) where studs are not present.
- 6) Place the base on the wall and secure it using the screws included.
- 7) Replace the circuit board on the base by first engaging the top of the circuit board under the two top latches; then gently press on the bottom of the circuit board until it snaps under the lower-right latch.
- 8) Install the spring (provided in the accessory pack) on the tamper switch.
- 9) Replace the cover on the repeater.

Example Intelligent Mode Repeater Installation

To install the system depicted in Figure 8:

- 1) Install the control panel.
- 2) “Learn” all of the sensors (sensors 1–8) into the control panel and then mount them.
- 3) Determine which sensors are distant from the control panel by performing a Dealer Sensor Test on all of the sensors. In this example, sensors 3–8 were determined to be the distant sensors.
- 4) “Learn” repeater 1 into the control panel.
- 5) Place repeater 1 between the control panel and a group of distant sensors (in this example, sensors 3 and 4).
- 6) Set the DIPs on repeater 1 to 00000001 (0 denotes OFF, and 1 denotes ON).
- 7) Perform a Dealer Sensor Test on the repeater.
- 8) Perform a Repeater Reception Test on all distant sensors to determine which sensors this repeater is able to repeat. For this example, only sensors 3 and 4 passed the test.
- 9) “Learn” sensors 3 and 4 into the repeater.
- 10) “Learn” repeater 2 into the control panel.
- 11) Set the DIPs on repeater 2 to 00000010.
- 12) “Learn” repeater 2 into repeater 1.
- 13) Place repeater 2 between repeater 1 and a group of distant sensors (sensors 5 and 6).
- 14) Perform a Repeater Reception Test between repeater 2 and repeater 1.
- 15) Perform a Repeater Reception Test on all remaining distant sensors (sensors 5 through 8) to determine which sensors this repeater is able to repeat. For this example, only sensors 5 and 6 passed the test.
- 16) Learn sensors 5 and 6 into the repeater.
- 17) “Learn” repeater 3 into the control panel.
- 18) Set the DIPs on repeater 3 to 00000011.
- 19) “Learn” repeater 3 into repeater 1.
- 20) Place repeater 3 between repeater 1 and the remaining distant sensors (sensors 7 and 8).
- 21) Perform a Repeater Reception Test between repeater 3 and repeater 1.
- 22) Perform a repeater reception test on all remaining distant sensors (sensors 7 and 8) to determine which sensors this repeater is able to repeat. For this example, sensors 7 and 8 passed the test.
- 23) Learn sensors 7 and 8 into the repeater.
- 24) Enable AC power failure and low battery reports for all repeaters installed.

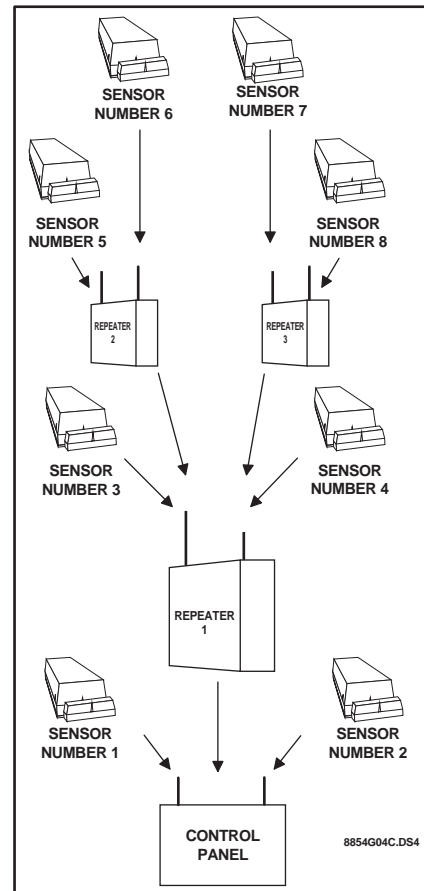

Figure 8. Example Repeater Installation (arrows denote communication links)

Specifications

Compatibility: CareTaker *Plus*, WatchGard, Concord, Concord Express, and Security Pro 4000 panels (with software 4.0 or later), SX-V *Special* (with software 7.0 or later), UltraGard (with software version 1.0 or later), and Safewatch Custom RF panels (with software 2.1 or later).

Power Requirements: Class II Transformer with a minimum 2 VA rating or DC power supply. 12 V lead-acid backup battery is optional.

Dimensions: 5.25" x 4.125" x 1.0" (L x W x D), excluding antennas.

Notices

This device complies with part 15 of the FCC rules. Operation is subject to the following two conditions:

- 1) This device may not cause harmful interference.
- 2) This device must accept any interference received, including interference that may cause undesired operation.

Changes or modifications not expressly approved by Interactive Technologies, Inc. can void the users' authority to operate the equipment

Note: The Quik Bridge Learn Mode Repeater is UL listed for Commercial Audio Transceivers (UL1270), but not for UL Fire or Burglary.



INTERACTIVE TECHNOLOGIES, INC.

2266 SECOND STREET NORTH
NORTH SAINT PAUL, MN 55109

T: 612/777-2690

F: 612/779-4890

W I R E L E S S

Security

Automation

Access Control

ITI and CareTaker are registered trademarks of Interactive Technologies, Inc. UltraGard and Quik Bridge are trademarks of Interactive Technologies, Inc.